

Lecture Note

On

Mechatronics

5th Semester

By

Prof. Ratikanta Sahu



Department of Mechanical Engineering

Raajdhani Engineering College

MECHATRONICS

Introduction to Mechatronics:

- The word mechatronics is composed of “Mecha “from Mechanical and the “tronics” from Electronics.
Mechanical + Electronics =
Mechatronics
- Mechatronics may be defined as the synergistic combination of precision mechanical engineering, electronics control and systems thinking in the design of products and manufacturing processes.
- It may be defined as the integration of electronics, control engineering and mechanical engineering.
Mechatronics involves a lot of technologies such as:
Mechanical engineering, electronic engineering, Electrical engineering, Computer engineering and Control Engineering.
- This can be considered to be the application of computer based digital control techniques, through electronics and electric interfaces to mechanical engineering problems.
- The term Mechatronics was coined by Tetsuro Mori, a senior Japanese engineer at the Yasakawa company in 1969, spread through Europe, and is now commonly used round the Globe.

Evolution levels of Mechatronics

Following are the evolution levels of mechatronics

- **Primary level Mechatronics:** This level incorporates input or output devices such as sensors and actuators that integrate electrical signal with mechanical action at basic control level. Examples: - Electrically fluid valves and relays.
- **Secondary level Mechatronics:** - This level integrates microelectronics into electrically controlled devices.
Example: - Cassette Player
- **Third level Mechatronics:** - This level incorporates advanced feedback functions into control strategy thereby enhancing the quality in terms of sophistication – called smart system.
Example:-Automatic washing machine, Control of electrical motor used to activate industrial robots.
- **Fourth level Mechatronics:** - This level incorporates intelligent control in mechatronics system. It introduces intelligence and fault detection and isolation (FDI) capability systems.

Advantages of Mechatronics

- The products produced are cast effective and very good quality.
- High degree of flexibility.
- A mechatronics product can be better than just sum of its part.
- Greater extent of machine utilisation.
- Due to integration of sensor and control system in a complex system capital expenses are reduced.
- Greater productivity.

Disadvantages of Mechatronics

- High initial cost of the system.
- It is expensive to incorporate Mechatronics approach to an existing or old system.
- Specific problems for various system will have to be addressed separately & properly.

Components of Mechatronic System

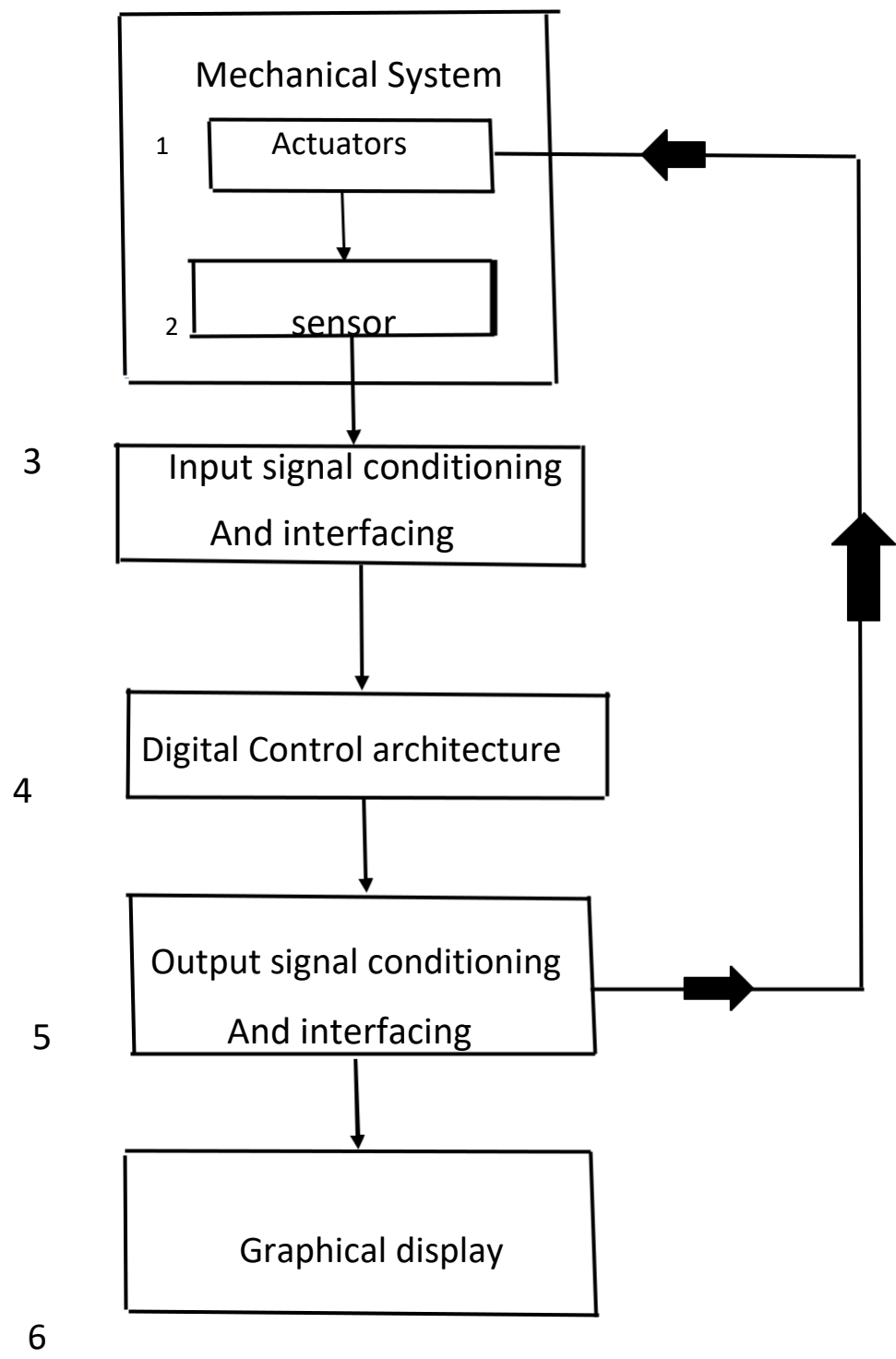

1. **Actuators:** - It produce motion or cause same action.
 - Solenoids, Voice coils, D.C. motors, Stepper Motor, servomotor hydraulics, Pneumatics etc.
2. **Sensors :-** It detects the state of the system parametersInputs and Outputs
 - Switches, Potentiometer, Photoelectric, Digital Encoder, Strain gauge, Thermocouple,Accelerometer.
3. **Input Signal conditioning and interfacing:** - It provides the connection between the controlcircuits and the input devices.
 - Discrete circuits, Amplifier, Filter, Analogue to Digital Converter etc.
4. **Digital Control architecture:** - It Controls the system.
 - Logic and arithmetic, Microcontroller, PLC, Sequencing and timing, Logic and Arithmetic,Control algorithm etc.
5. **Output signal conditioning and interfacing:** - it provides the Connection between the control circuits and the output devices.
 - Digital to analogue converter, Amplifiers, PWM, Power Transistors, Power op-amps.
6. **Graphical Displays:** - It provides visual feedback to users.
 - LEDs, Digital displays, LCD, CRT.

Application of Mechatronics

- Automotive Mechanics
- Fax and photocopier Machine.
- Dish washer.
- Air conditioners, elevators controls.
- Automatic Washing Machines.
- Flexible Manufacturing System.
- Document scanner
- VCRs and CD players.
- Integrated circuits manufacturing system.
- Robotics employed in welding, Nuclear Inspection etc.

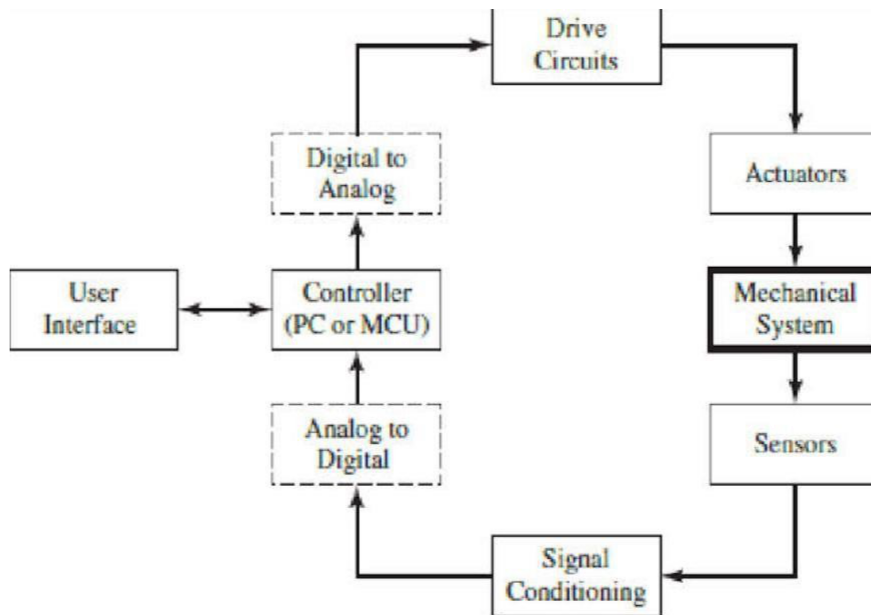

Scope Of mechatronics in Industrial Sector

- Better design of Products
- Better process planning
- Reliable and Quality – oriented manufacturing
- Intelligent process control

Robotics

Robotics may be defined as the science of designing and building robots Suitable for real life applications in automated manufacturing and other non-manufacturing environment. Robotics is the art, knowledge base and know how of designing, applying and using robots in the human endeavors.

Laws of Robotics

Following are the three basic laws of robot a proposed by Sir Issac Asimov in 1940 and the zeroth law was added on later.

Zeroth law - A robot must not Injure humanity or through inaction, allow humanity to come to harm. **First law**- A robot must not harm a human being or through inaction, allow one to come to harm.

Second law- A robot must always obey human beings unless it is in conflict with higher order law. **Third law** -- A robot must protect itself from harm unless that is in conflict with a higher order law.

Definition of Robot

The term "Robot" is known to have been derived from a czech word Robota which means slave labourer or forced labourer.

Many efforts have been made by different people to define robots In their own way however the most widely accepted definition is given by the Robot Institute of America (now known as Robotic Industries Association) RIA, which is as follows:

"A robot (Industrial Robot) is a programmable, multifunctional manipulator designed to move materials, parts, tools or special devices through variable programmed motions for the Performance of a variety of tasks."

According to ISO (International Standard Organization) "An Industrial Robot may be defined as an automatic, servo-controlled, freely programmable, multipurpose manipulator with several area for the handling of workpieces, tools or special devices. Variably programmed operations make the execution of a multiplicity of tasks possible"

Objectives of using Industrial Robots.

- To increase productivity.
- To raise the quality level of products.
- To minimize the labour requirement
- To reduce Production time.
- To improve existing manufacturing Processes.
- To enhance the life of production machines.
- To increase the safety level of the labour by replacing them by robots.

Functions of a Robot

The functions of a Robot can be classified into three areas

- **Sensing** the environment by external sensors.
- **Decision making** based on the information received from the Sensor.
- **Performing** the tasks decided.

Types of Industrial Robots

Industrial robots can be broadly divided into two main group

- i) General Purpose robots
- ii) Special purpose robots

General purpose Robots: - These robots carry standard designs and parts and are readily available.

They Can be easily adapted to the user's requirement by attaching suitable end effectors or fingers to them. According to the requirement of the work such as a part picking operation, welding operation, spray painting etc.

Since such robots are mass produced and Cheaper.

Special Purpose robots: - These robots are tailor made to specific job requirements.

The ultimate user has to feed his requirements and based on them, those robots are specially designed and built to cater to such specific needs.

The designing and manufacturing of these types of robots consumes a lot of time. As such they cannot be readily available in Market. They cannot be manufactured on mass scale and they are very costly.

Robotic Systems

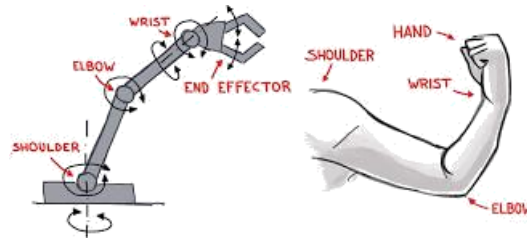

A robot (Industrial Robot) is also called a robotic manipulator or a robot arm.

A robot is a system as it combines several Subsystems that interact themselves as well as with the environment in which the robot works. A robot carries a large number of components of which the main components are the following

Base: - It can be fixed or mobile.

Manipulator Arm: - With a number of degrees of freedom of movement, The manipulator arm with specified reach in the Coordinate systems to attain a designed in working space.

Gripper or End-effectors: - It is used for holding a piece or a tool, depending upon the application of the robot. A suitable gripper to match the geometry of the work piece to be handled.

Drives: - It is also known as actuators, they move the manipulator arm and end effector to the required position in space.

Control system: - A suitable control system with or without servo mechanisms for sending signals to the drives, or permit to storage of programmes and data for desired path planning with required speed and good accuracy.

Controller: - It is provided with interfacing units connected to external equipment in the outside world. It delivery Commands to the actuators with the help of hardware and software support. **Sensors:** - They perform dual functions,

- i. To act as feedback devices to direct further actions of the manipulator arm and the end effector (gripper)
- ii. To interact with Robots working environment.

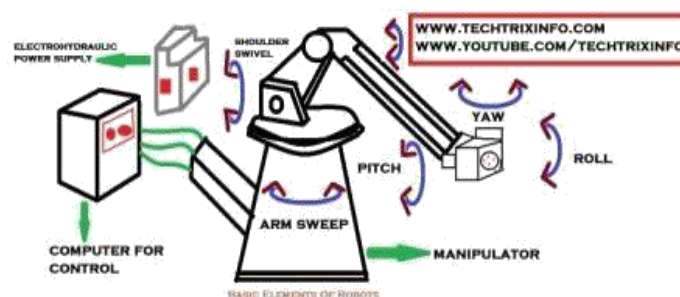

Degree of freedom of Robot manipulator Arm The

six are a basic motions or degrees of freedoms.

Vertical motion: - The entire manipulator arm can be moved up and down vertically either by means of the shoulder swivel i.e. turning it about a horizontal axis or by sliding it in a vertical

slide.

Radial motion: - Radial movement i.e. in and out movement to the manipulator arm is provided by Elbow extension by extending it and drawing back.

Rotational motion: - Clockwise or anticlockwise rotation about the vertical axis to the manipulator arm is provided through Arm Sweep

Pitch motion: - It enables up and down movement of the wrist and involves rotational movement as

Well. It is also known as wrist bend.

Roll motion: - It is also known as wrist swivel, it enables rotation of wrist. **Yaw:** - It is also called wrist yaw. It facilitates rightward or leftward Swiveling movement of the wrist.

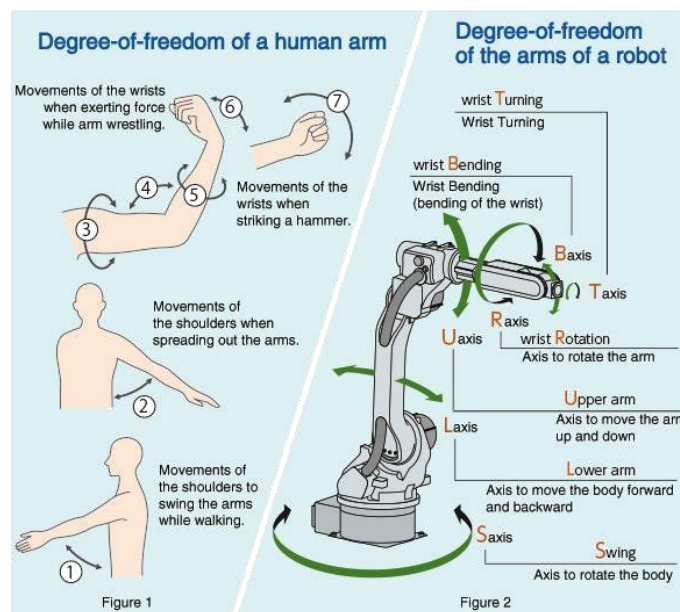

Robot classification

1. Standard classification,
2. Broad classifications,
3. General classifications

Standard classifications classify the industrial robots are:

1. Mechanical configuration based – it can be grouped
 - i) Cartesian co-ordinate Configuration
 - ii) Cylindrical configuration
 - iii) Spherical configuration
 - iv) Jointed-arm configuration
2. Control method based:- It may be subclasses into
 - i) Non - Servo controlled
 - ii) Servo controlled

Broad classification - Robots can be broadly classified as

- i) Programmable /reprogrammable general purpose robots
- ii) Tele operated, man-controlled robots
- iii) Intelligent robots

General classification - According to general method of classification Robots can be classified as

- i) Special purpose Robots
- ii) General purpose Robots - It may be sub divided into
 - Non- Servo Controlled robots
 - Servo controlled robot
 - Sensory robot.

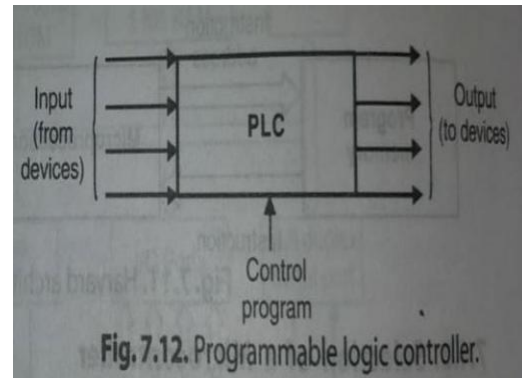

Fig.7.12. Programmable logic controller.

Advantages of Industrial Robots

- Lifting and moving objects
- Working in hostile environments.
- Working during unfavorable hours.
- Increasing productivity, Safety, efficiency and quality of products.
- Achieving more accuracy than human beings.

Disadvantages of Industrial robot

- The robots lack capability to respond in emergencies.
- The initial and installation costs of equipments of robots are quite high.
- They replace human workers, thus causing resentment among workers.

PROGRAMMABLE LOGIC CONTROLLERS (PLCs)

PLCs are specialised industrial devices for interfacing to and controlling analog and digital devices -

They are designed with a small instruction set suitable for industrial control applications.

-They are usually programmed with "ladder logic", which is graphical method of laying out the connectivity and logic between system inputs and outputs.

- They are designed with industrial control and industrial environments specifically in mind. Therefore, in addition to being flexible and easy to program, they are robust and relatively immune to external interference.

Advantages of a PLC:

The advantages of a PLC are

1. Low cost.
2. Easy to install.
3. Ensures increased productivity.
4. Faster operational speed.
5. Provides high reliability and easier maintenance.
6. Can withstand harsh industrial environment/manufacturing environment

7. Provides consistency in manufacturing.
8. Can input/output both analog and digital signals.
9. Reduced cost of scrap and rework (since the user / designer can change the PLC program without changing any hardware or scraping the present hardware).
10. Small size.
11. PLC modules can be added, depending upon the input/output requirements.
12. Easier troubleshooting.

Selection of a PLC

For selection of a PLC, the following criteria need to be considered:

- 1.Types of inputs/outputs required, such as:
 - Isolation;
 - Out-board power supply for inputs/outputs;
 - Signal conditioning.
2. Input/Output capacity required.
3. Size of memory required. This is linked to the number of inputs/outputs and complexity of program used.
4. Speed and power required for CPU-This is linked to the number of instructions that can be handled by a PLC. types

Architecture basic internal structure

A PLC consists of the following main components :

1. Central processing unit (CPU):
- 2 Memory
3. Input/Output circuitry.

1. Central processing unit (CPU):

- It controls and processes all the operations within the PLC.

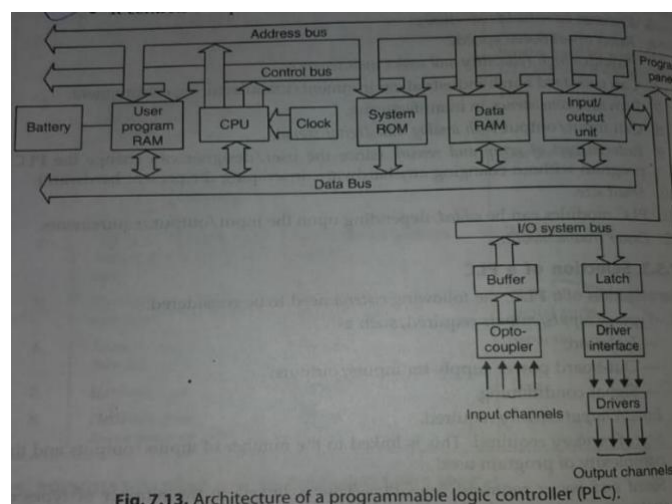

Fig. 7.13. Architecture of a programmable logic controller (PLC).

- It is provided with a "clock" with a frequency of typically between 1 and 8 MHz. This frequency determines the operating speed of the PLC and provides the timing and synchronisation for all elements in the system.
- A "bus system" carries information and data to and from the CPU, memory and

input/output units.

Memory: The various memory elements available in a PLC are:

- (i) A system ROM to give permanent storage for the operating system and fixed data.
- (ii) RAM for user's program.
- (iii) Temporary buffer stores for input/output channels. • The programs in RAM can be changed by the user. However, to prevent the loss of these programs when the supply is switched off a battery is likely to be used in the PLC to maintain the RAM contents for a period of time.

3 Input/Output (I/O) circuitry: The I/O unit provides the interface between the system and outside world.

- Programs are entered into the I/O unit from a panel which can vary from small keyboards with liquid crystal displays to those using a visual display unit with keyboard and screen display. The programs, alternatively, can be entered into the system by means of a link to a personal computer which is loaded with an appropriate software package.
- The I/O channel provides signal conditioning and isolation functions so that sensors and actuators can be generally directly connected to them without the need for other circuitry.
- The basic form of programming commonly used with PLCs is ladder programming. This involves each program task being specified as though a rung of a ladder. specify that the state of switches A and B, the inputs, be examined and if A and B are both closed then a solenoid, the output, is energised.
- A PLC, when carrying out a program, follows the sequence indicated L. Scanning the inputs associated with a rung of the ladder
 1. Solving the logic operation involving these inputs.
 2. Setting/resetting the outputs for that rung
 3. Moving on to the next rung and repeating operations 1, 2, 3.
 4. Moving on to the next rung and repeating operations 1, 2, 3.
 5. Moving on to the next rung and repeating operations 1, 2, 3.
 6. Moving on to the next rung and repeating operations 1, 2, 3; continuing until
 7. end of the program.
- For input/output processing the following two methods are used:

- 1. Continuous updating:
 - In this method the CPU scans the input circuits as they occur in the program instructions. Each input point is examined individually and its effect on the program determined.
 - There will be a built-in delay, typically about 3 ms, when each point is examined in order to ensure that only valid input signals are read by the microprocessor. This delay enables the microprocessor to avoid counting an input signal twice, or more frequently, there is contact bounce at a switch. A number of inputs may have to be scanned, each with a 3 ms delay, before the program has the instruction for a logic operation to be executed and an output to occur. The outputs are latched so that they retain their states until the next updating.
- 2 Mass input/output copying
 - In case of continuous updating method since there has to be a 3 ms delay in each point therefore, the time taken for examining several hundred input/output points can become comparatively long.
 - In order to have a more rapid execution of program, a specific area of RAM is used as a buffer store between the control logic and input/output unit. Each input/output has an address in this memory. At the start of each program cycle the CPU scans all the inputs and copies their
 - status into the input/output addresses in RAM. As the program is executed logic operations are carried out. The resulting output
 - signals are stored in the reserved input/output section of RAM. At the end of each program cycle all the inputs are transferred from RAM to the output channels. The outputs are latched so that they retain their status until the next updating.
 - Programming: When a PLC programming is carried out, using ladder diagrams, a program is written in a similar manner to drawing a switching circuit.
 - The ladder diagram consists of two vertical lines representing the power rails. Circuits are connected as horizontal lines, i.e., the rungs of the ladder between these two vertical lines. While drawing the circuit line for a rung, inputs must always precede outputs and there must be at least one output on each line. Each rung must start with an input or a series of inputs and end with an output. The inputs and outputs are numbered, the notation used depending upon the manufacturer of PLC.

- Logic function: AND, OR, NOR, NAND, EXCLUSIVE-OR(XOR) • Latching: Sometimes there are situations where it is necessary to hold a coil energised, even when the input which energises it ceases. The circuit which is
- used to carry out such an operation is termed as latch circuit. It is a self-manufacturing

Mnemonics

In a ladder program each horizontal rung on the ladder represents a line in the program and entire ladder gives the complete program in 'ladder language'. The programmer can enter the program into the PLC using a keyboard with the graphic symbols for the ladder elements, or using a computer screen and a mouse to select symbols, and the program panel or computer then translates these symbols into machine language that can be stored in the PLC memory. Alternatively, a program can also be entered by translating the ladder program into mnemonics", each code corresponding to a ladder element, and then enter these into the programming panel or computer. These are then translated into machine language. The mnemonics used by different PLC manufacturers differ.

Master and Jump Controls

A whole block of outputs can be simultaneously turned off or on by using the same internal relay contacts in each output rung so that switching it on or off affects every one of the relay rungs. An alternative way of programming to achieve the same effect is to use a master

- Jumps. A function which is often provided with PLCs is the conditional jump function. Such a function enables programs to be designed so that if a certain condition exists then a section of program is jumped.

Numerical Control (NC)

-NC (numerical control) machine tools are the machine tool, of which the various functions are controlled by : letters, numbers and symbols.

The NC machine tool runs on a program fed to it; without human operator. The NC program consist of a set of instruction or statement for controlling the motion of the drives of the machine tools as well as the motion of the cutting tool.

NC machine tools, one or more of the following function may be automatic :

- Starting and stopping of the machine tool spindle;
- Controlling the spindle speed;
- Positioning the tool at the desired location and guiding it along the desired path by automatic control of the motion of slides;
- Controlling the feed rate; and Components of NC machine tool system

Components of nc machine tool system

1. Part program:

Using the part drawing and the cutting parameters, the part program is written. The part program is a set of step by instruction to the machine tool for carrying out the operation.

. Method use for part programming

. Manual part programming

. Computer-aided part programming

2. Program Tape

The part program is entered on the program tape.

The program is entered on the tape in the form of punched holes. The holes are punched with the help of punching machine.

3. Machine Control Unit(MCU):

The program tape is read by the tape reader.

The controller takes input from the tape reader.

4. **Machine Tool:** The machine tool is operated by the controller of the machine control unit Motion Control Systems

Motion control system

1. Point-to-Point systems

- Also called position systems
- System moves to a location and performs an operation at that location (e.g., drilling)
- Also applicable in robotics

Motion Control Systems

2. Continuous path systems

- Also called contouring systems in machining
- System performs an operation during movement (e.g., milling and turning)

Absolute vs. Incremental Positioning

Absolute positioning Move is: x- 40, y 50

Incremental positioning Move is: X- 20, y – 3

0.

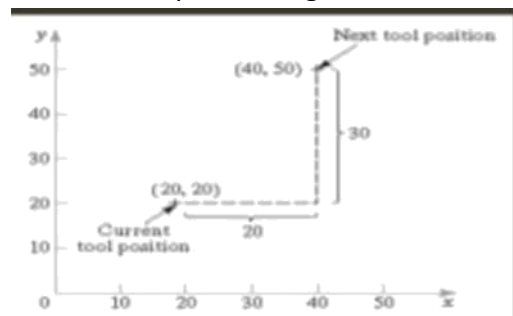

Absolute vs. Incremental Positioning

Absolute positioning Move is: x- 40, y 50

Incremental positioning Move is: x=20 y=30

Advantages of NC machine tool

Cycle time reduction

- Complex machining operation

- High degree of accuracy

Limitation of NC machine tool

- Less inspection required
- Reduction of scrap and wastage
- Increasing productivity
- Lower tooling cost
- Reduction of human error
- Greater operation safety
- Greater operation efficiency
- Reduction space required
- Operator skill-level reduced
- High investment cost
- High maintenance effort
- Need for skilled programmers
- High utilization required

Classification of NC machines : NC machines may be classified follows :as

A. According to control system:

1. **Point-to-point system**- The machining is done at specific position Example : Drilling machine operation
2. **Straight line system** - It is an extension of point to point system Example : Stepped turning on lathe, poded milling etc.
3. **Contour system** - There are continuous, simultaneous and o-ordinated motions of the tool and workpiec: along different coordinate axes. Example Machining of profiles, contours and curved surfaces

Applications of NC machines : (the major applications of NC machines are

1. Complex parts.
2. Parts which are frequently subjected to design changes.
3. Repetitive and precision quality parts which are to batch quantity.
4. To cut down lead time in manufacture. be produced in low to medium
5. In situations where the investment on tooling and fixture inventory will be high if parts are made on conventional machines tools.

Advantages of NC machines : Following are the advantages of NC machines :

1. Accuracy achieved is of high order.
2. Reduced production cost per piece.
3. Less scap.
4. High production rates.
6. Excellent reliability.
7. Tooling cost low.

8. Less cycle time and increased tool life.
9. Increased flexibility.
10. Production of complex part

Procedure for manufacturing through NC

The sequence of manufacturing through NC starts with the Engineering Drawing of the part to be produced. This drawing is first received by the Process planning department where it is analysed and interpreted in terms of the processes of manufacturing and their sequence to be used for producing that part. This enables the preparation of the Process sheet for the part.

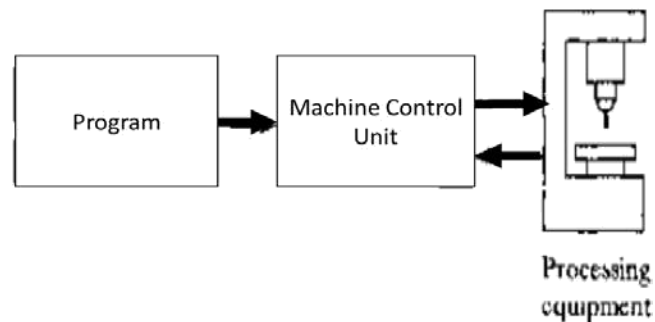

This process sheet is used for the following:

- > Tool designing
- > Fixture designing
- >Deciding tooling details
- > Preset tooling
- > Part programming.

The step that follows process planning is Programming more precisely Part programming. This involves planning of the machining sequence, relative positions of cutting tool and workpiece at each step of the operation and necessary instructions for machining This programming can be done both manually and with the use of computer. The former is known as Manual part programming (MPP) and the latter as Computer assisted part programming (CPP). In the former case, the machining instructions are recorded in a special format, called manuscript. In the latter case, the process sheet is handled by the computer to interpret the contained instructions, prepare necessary commands for machining and prepare the tape for the NC machine tool. Usually, simple programmes, involving simple part shapes are handed manually and those involving complex shapes and consequently tedious computation work by computer .the use of computer obviously enables a considerable saving of time in part pargramming The next step to follow in either case is the Preparation of tape. In the first case, ie.MPP, a punched tape is prepared from the manuscript. In the second case, the computer itself controls and directs a machine to punch the tape according to its instructions. In both the cases, tis necessary to check the punched tape for errors, if any, and correct these. Depending upon the type of infra-structure available for tape preparation, and that in MCU, the programme on tapes or written on magnetic cassettes, floppy discs, disc drive of a mainframe computer or a MCU keyboard, used for this purpose. can be punchedThe actual machining (production) work starts only after all the above

steps are over. The machine is properly checked and set, with all the cutting tools in proper positions, and a trial run made if necessary. Then the machine tool is set to the "Start" position, raw material loaded in it and the machine started. The rest of the entire cycle of production is taken care of by Numerical Control is, through the commands and instructions given by the punched The above NC production procedure is diagrammatically

Computer Numerical Control (CNC)

It is a software-based system, in which the computer replaces the entire unit of the conventional NC. It does not carry the hard-wired logic systems and all their functions for controlling the machine tool are performed by the software programme of the computer. That's why it is known as a software-based system. Also, since a separate computer is used for each machine tool, with a stored programmable logic, it is known as a self-contained NC system for that particular machine tool. The computer used is known as a Dedicated or mini computer

The main objective of using this system is to simplify the hardware of conventional NC and replace it with the software to the maximum possible extent. The programme is entered into the computer through a tape or keyboard and stored in its memory, which can be called whenever a part is to be machined. Also, it is easy to edit and modify a programme when it required. Thus, the programmed tape is required only once for feeding the programme into computer memory and the repeated use of tape reader is eliminated, unlike conventional NC. This results in considerable saving of time and cost and increased reliability. An added feature in this system is the diagnostic software, which enables easy trouble shooting if the CNC system fails to operate. The problem can be easily detected and rectified through this software.

CNC MACHINE

CNC machine used a minicomputer to control machine tool functions from stored tours information or punched tape input or computer terminal input. The definition CNC (Computer Numerical Control) as given by EIA as under: The numerical control system where a dedicated, stored program computer is used to perform

Functions of CNC :

the principal functions of CNC are :

1. Machine tool control
2. In-process compensation.
3. Improved programming and operating features.
- 4 Diagnostics.

Advantages of CNC machines :

CNC machines offer the following advantages in manufacturing:

1. Greater flexibility.
2. Reduced data reading error.

3. Increased productivity.
4. Consistent quality.
5. Automatic material handling.
6. Elimination of operator errors.
7. Reduced operator activity.
8. Lower labour cost.
9. Smaller batches.

Disadvantages of CNC machines :

1. Higher investment cost.
2. Higher maintenance cost.
3. Costlier CNC personnel.
4. Airconditioned places are required for the installation of the machines
5. Unsuitable for long run applications.
6. Planned support facilities.

Applications of CNC :

CNC is being used in the following machines/areas:

- Drilling machines.
- Turning machines.
- Boring machines.
- Milling machines.
- Grinding machines.
- Pipe bending machines. • Coil winding machines.
- Flame cutting machines. EDM and Welding, wire cut malfunction in several other areas.

Introduction to CNC Machine Tools

- In CNC (Computer Numerical Control) machines, a dedicated computer is used to perform the most of basic NC machine functions.
- CNC (Computer Numerical Control) machine is a NC machine which uses a dedicated computer as the machine control unit.
- The entire program is entered and stored in computer memory. The machining cycle for each component is controlled by the program contained in the computer memory.
- The stored part program listing can be used for future production also.

Components of CNC machine tool system

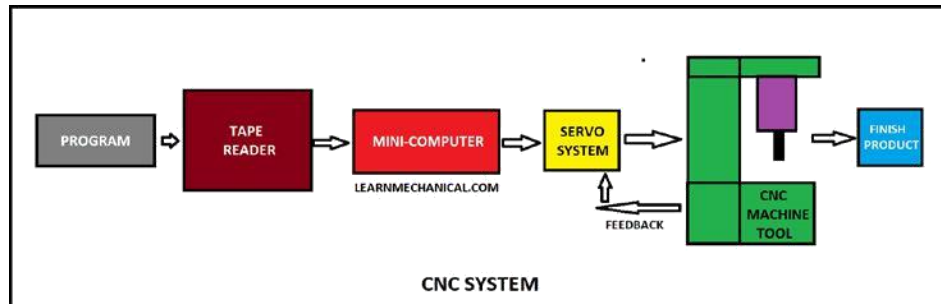

- The main components of CNC machine tools are as follows:
 1. Input / Output Console.
 2. Microprocessor Based control unit.
 3. Memory
 4. Feedback unit.
 5. Machine Tool.
 6. Interfaces.
- Input / Output Console It is the unit through which part program is fed to the CNC machine tool system and required output is taken out. It basically consists of monitor and Keyboard.
- Microprocessor : This controller takes input from Input / Output device, Feedback from feedback unit and actuates the drives as well as the tool of the machine tool.
- Memory : It consists of RAM & ROM. The RAM stores part program, while ROM stores the programs for machine control.
- Feedback unit. The feedback unit takes input from machine tool and transfers it to control unit for necessary corrections
- Machine tool Machine tool is operated by the control unit,
- Interfaces They are the connections between the different components of the CNC machine tool system

CAD

In the modern sense, CAD (Computer Aided Design) is defined as "A design process using sophisticated computer graphics techniques, backed up software package to aid in the analytical, development, costing and ergonomic problems associated with computer with design work"

Advantages :

The following are the advantages of CAD

1. Drawings can be produced at a faster rate.
2. Drawings produced by CAD systems are more accurate and neater.
3. In this system there is no repetition of the drawings
4. CAD systems assimilate several special draughting techniques which are available with conventional means.
5. Design calculations and analysis can be carried out quickly.

6. With CAD systems superior design forms can be produced.
7. CAD simulation and analysis techniques can drastically cut the time and more spent on prototype testing and development - often the costliest stage in the design process.
8. Using CAD systems design can be integrated with other disciplines.

CAM

CAM (Computer-Aided Manufacture) concerns any automatic manufacturing process which controlled by computers.

The most important elements of CAM are :

1. CNC manufacturing and programming techniques.
 2. Computer controlled robotics manufacture and assembly.
 3. Flexible Manufacturing Systems (FMS).
 4. Computer Aided Inspection (CAI) techniques.
 5. Computer Aided Testing (CAT) techniques.
-
1. Product obtained is superior in quality.
 2. The manufactured form has a greater versatility.
 3. Higher production rates with lower work-forces.
 - 4 There is less likelihood of human error.
 5. As a result of increased manufacturing efficiency cost savings are materialised
 6. The production processes can be repeated via storage of data

Software and hardware for CAD/CAM

The functions of CAD/CAM systems are mainly determined by the software. Software usually consists of a number of separate application packages to perform desired function. The size of computer depends on the number and sizes of packages and number of work station

Functioning of CAD/CAM system CAD/CAM is an interactive computer graphic tool that enhances design and manufacturing functions to create a highly profitable product. This technique is being applied by big industries for improving overall manufacturing performance

• It is not a standard tool which can be fitted into any company but has to be tailored to suit the needs of the company. It is rather complex technology and has wide potential for immediate benefits.

• Usually this tool consists of a dedicated computer, which is connected to a number of work-stations. The system is used to assist in the design and manufacturing, through the use of an expandable set of linked software modules. A designer can define dimensions and display views of 2 dimensions, 2 dimensions and 3 dimensions parts on modules. It is possible to generate the families of part directly by a parametric processor either by direct scaling or using a catalogue of subprograms.

From the geometric definition a solid model can be constructed to assist in visualisation. It is possible to store complete details of designs on numerical control types for subsequent use on demand. Bench making tests are carried out to ensure system's capability.

Features and characteristics of CAD/CAM systems

The following are the features and characteristics of CAD/CAM system :

1. A major portion of the output of the engineering sector involves batch production and CAD/CAM offers immense cost and quality benefits for such requirements.
2. The work-in-progress, in batch production, is reduced considerably
3. It is possible to produce at random all the variants and series of a product planned to be manufactured by a firm.
4. Such a system has inherent flexibility to cater to new models of the product in pipeline without major modification
5. In such a system, several machining centres are arranged one after the other with robots and proper automatic materials handling equipment. Software is developed to integrate the machine CNC control and the handling system. Each machining centre is equipped with several tool magazines. All the tools required to complete each operation on each model of the product can be stored in the magazine.
6. All the part programs for the different models are stored in the memory. System has only to identify the model of the product presented to a machine in order to complete the machining operations. Thus it is possible to have totally random mixes of models of a product proceeding down the line at any one time.
7. The system can be conceived in multiples of 15-20 minutes operations. If certain operations take longer, then multiples of similar machines can be installed in the line. Sometimes identical machines are introduced for each operation so that production can continue even if one machine goes down.

The components are loaded on to a pallet. Means are provided to identify exact model.

- Loaded pallets enter the line and wait at the start of the line until a signal. The handling system automatically directs the pallet to the first vacant machine. One of the first operation machines is vacant is obtained. The pallets are loaded on a fixture. The fixture is designed so that it permit access to all four sides and end faces and wherever machining operation is required. The pallets are designed to have windows where access for machining is required.

- As the pallet enters the machining area, air blast clears both the fixture and pallet locations. The fixture is then properly clamped and supported. Touch trigger probes are used to check its location in the pallet.

- Probes also identify the exact model of the component and signals from the probes activate calling program which selects the appropriate part program and sub-routines from the control memory.

- An overhead cascade coolant wash is provided to clear away swarf before the pallet is located. All coolant and swarf is carried away via underground ducts to a central separation and coolant filtration plant.

Some systems can show metal being removed dynamically: . It is possible to store libraries of standard tools and tool holders, thus carrying out process planning.

- By calling up and manipulating standard fixturing components, like studs, stops clamps, bushes,

location devices, fixtures etc., it is possible to design a fixture for a component already designed on the CAD/CAM system.

- It also allows sheet metal development (unfolding), taking account of the material for the bends. It is also possible to layout sheet metal components on one standard sheet to reduce the waste (nesting). Factory layout process planning and robot programming have also been attempted.

. Exploded views, schematics and diagrams, 3-D colour shades like photographs • views of the parts can be produced. soubin ol .

- Tenders and estimates can be quickly produced to high quality.

Application areas for CAD/CAM The potential application areas for CAD/CAM

1. Design and design analysis :

- CAD system would be best suited for drawing offices where frequent modifications are required on drawing and several parts repeat.

- It must be remembered that it is very easy with computer to make modification and very fast to draw part profile once its details are fed into computer. • Once a drawing is entered in the CAD system, later modifications can be done quickly, and detail drawings can be prepared quickly from a general arrangement drawing

- NC tapes can be produced.

- Storing of the drawing is very convenient, easy, occupies very little space for electrical, hydraulic, control and instrumentation circuits can be called up quickly and positioned on the schematic drawing. less space

Standard components can be stored permanently in the data base and called up positioned on the drawing, resulting in saving of time and enforcement of standards. It is possible to associate nongraphical information like part number, supplier, material etc., for any component assembly. It is very convenient to calculate properties like weight, centre of gravity, moment of inertia, etc., because 3-D models can be easily produced. It is also possible to carry out finite element analysis by producing meshing for analysis.

2 Manufacture :

- With CAD/CAM system the complete NC part programming process can be carried out interactively, including post processing and production of NC tape. Source programs in languages such as APT can be produced. Systems can verify tapes by producing tool centre path plots.

ELEMENTS OF CNC MACHINES

Computer Numerically Controlled (CNC) machine is a mechatronic system since the machine tool which is a mechanical system is incorporated or integrated with the electronic controls for its different drives and computer system for interfacing the software with the mechanical and electronic system.

Hardware or electronic circuits control the motions of various drives.

The design and construction of CNC machines differs greatly from that of conventional machine

tools. This difference arises from the requirement of higher performance levels. The CNC machines often employ the various mechatronic elements that have been developed over the years. However, the quality and reliability of these machines depends on these machines depends on various elements and subsystems of the machines. The following are some of the important constituent parts, and aspects of CNC machines to be considered in their designing:

1. Machine structure.
2. Guideways/Slideways.
3. Drives.
4. Spindle and spindle bearings.
5. Measuring systems.
6. Controls.
7. Gauging
8. Tool monitoring.
9. Swarf removal.
10. Safety

Machine Structure

The "machine structure" is the load carrying and supporting member of the machine tool. The design and construction of CNC machine should be such that it meets the main objectives"

- High precision and repeatability,
- Reliability;
- Efficiency.

In order to meet these requirements, the numerically controlled machine tools should have a structure with the following characteristics:

1. It does not deform or vibrate beyond the permissible limits under the action of static and dynamic forces, to which it is subjected.

- **Static load** of a machine tool results from the weights of slides and the workplace, and the forces due to cutting.

- **Dynamic load** is a term used for the constantly changing forces acting on the structure while the movement is taking place. These forces cause the whole machine to vibrate and the origin of these vibrations may be due to unbalanced rotating parts, improper meshing of gears, bearings irregularities, and interrupted cuts while machining (as in milling). These vibrations can be reduced by : (i) Improving the damping properties, (ii) Reducing the mass of structure and increasing the stiffness of the structure

2. Its design should be such that the thermal distortion is minimum. The machine tool should be protected from external and internal heat sources, some of these heat sources are: Electric motor, friction in mechanical drives, gear boxes, bearings and guideways; machining process; temperature of surrounding objects.

- Thermal deformation due to thermal load may be reduced by:

- Designing the structure thermo-symmetrically.
- External mounting of drives.
- Using a proper lubrication system for removing frictional heat from bearings and guideways.
- Removing the coolant and swarf efficiently for the dissipation of heat generated from the machining process.

3. The machine structure design should be such that the removal of swarf is easy the chips etc., do not fall on the slideways.

Guideways/Slideways

In machine tools the guideways are used to serve the following purposes

- To control the direction or line of action of the carriage or the table on which a tool or a work piece is held.
- To absorb all static and dynamic loads.

The guideways may be an integral part of the machine structure or may be mounted separately on the structure. These guideways may be horizontal, vertical or inclines however vertical and inclined guideways are preferred so that chips produced during the cut operation do not get collected on the quick ways.

The shape and size of the work produced depends on the accuracy of the movement and kinematic accuracy of the guideway. Kinematic accuracy depends on the straightness flatness and parallelism errors in the guideway.

In a CNC machine the design of guideway/slideway should:

- Reduce friction;
- Reduce wear;
- Satisfy the requirements of movement of the slides;
- Improve smoothness of the drive

Factors influencing the design of guideways

The following factors should be considered while designing guideways:

- Geometric and kinematic accuracy.
- Position in relation to work area.
- Provision for adjustment of play.
- Rigidity.
- Damping capability.
- Velocity slide.
- Friction characteristics.
- Wear resistance.
- Protection against swarf and damage.
- Protective guards to safeguard the guideways.
- Freedom from unnecessary restraints.
- Effective lubrication and efficient lubrication.

Types of guideways

Guideways are broadly classified as follows:

1. Friction guideways

- Vee guideways.
- Flat guideways

- Dovetail guideways.
- Cylindrical guideways

2. Antifriction linear motion (LM) guideways.

3. Frictionless guideways

- Hydrostatic guideways.
- Aerostatic guideways.

Other types of guideways employed in machine tools are:

1. Hydrostatic guideways.

2. Aerostatic guideways

DRIVES

Drives are devices which impart motion to mechanical elements,. In a CNC machine tool there are three major groups of elements:

- Control and electronics
- Electric drives (electromechanical drives)
- Mechanical elements (table, slide, tool holder etc)

In addition, there can be hydraulic and pneumatic systems which are integrated with CNC machine tool.

The primary function of the drive is to cause motion of the controlled machine tool member (spindle, slide, etc) to conform as closely as possible to the motion commands issue by CNC system. In order to ensure a high degree of consistency in production, variable speed drives are essential.

Most of the drives used in machine tools are electrical.

Depending on their characteristics, machine tool drives can be classified as follows:

1. Spindle drives ... (constant power)

(i) D.C spindle drives:

- Separately excited D.C. shunt motor.
- Controller:

- Thyristor (SCR) amplifier,
Or Microprocessor based self-tuned thyristor amplifier.

- Speed control:

- Armature and field control.

(ii) A.C. spindle drives:

- Squirrel cage induction motor.

- Controller:

-Microprocessor based pulse width modulated (PWM) inverter

- Speed control:

- Frequency, vector control

2. Feed drives ... (constant torque)

(i) D.C. servo-drive:

- Motor - permanent magnet.

- Controller:

-Thyristor D.C. amplifier

-Transistor PWM D.C. chopper

- Speed control

-Armature voltage

(ii) A.C. servo-drive

- Motor - Synchronous three phase A.C. motor with permanent magnet rotor

- Controller:

- Transistor for PWM frequency inverter; analog drive amplifier Transistor PWM frequency inverter; digital drive amplifier

- Speed control

Spindle drives

The following motors are used in spindle drives:

- i) D.C. shunt motor (separately
- ii) Three-phase A.C. induction motor

The requirements of a spindle drive motor are:

- Compactness.
- High overload capacity.
- Large speed range of at least 1:1000
- Maximum speeds up to 9000 - 20000 rpm.
- High rotational accuracy..
- Range of rated output from 3.7-50 KW.-
- Wide constant power band
- Fast dynamic respond
- Excellent running smoothness

CNC machines the D.C. spindle drives are commonly (say for stepless speed variation of spindles). However, with the advent of microprocessor based AC. frequency inverter, of late, the A.C. drives are being referred to D.C. drives as they offer several advantages (e.g., more reliable, easily maintainable and less costly)

The main advantage of microprocessor-based frequency converter is the possibility of using the spindle motor for C-axis of 1: 10° with positioning.

Feed drives

The main components of a feed drive are :

- (i) A feed servomotor;
- (ii) Mechanical transmission system.

A "feed motor", unlike a spindle motor, has special characteristics like constant torque and positioning. In continuing operations where a prescribed path has to be followed continuously, several feed drives have to operate simultaneously; this requires a sufficiently damped servo system with high band width, i.e., fast response and matched dynamic characteristics for different axes.

Following are the requirements of CNC feed drive:

- High torque-to-weight ratio.
- Integral mounting feedback devices.
- During machining the required constant torque for overcoming frictional and working forces must be provided.
- Low electrical and mechanical constants.
- Low armature or motor inertia.
- Permanent magnet construction.
- Total enclosed non-ventilated design.
- Maximum speed up to 3000 r.p.m.
- The drive should be infinitely variable with a speed range of at least 1: 20,000
- Positioning of smallest position increments like 1-2 μm should be possible.
- Four quadrant operation - quick response characteristics.
- High peak torque for quick responses.

For CNC machines the commonly used feed drives are DC and A.C. servomotors. Although earlier D.C. servomotors, because of their excellent speed regulation, high torque and efficiency, were used most commonly on CNC machine, but now A.C. servomotors have become more popular for machine tool applications because of the following characteristics.

- Higher reliability as compared to D.C. servomotors.
- Provides a constant torque over their entire speed range.
- Provides less maintenance
- Provides a better response and dynamic stiffness.
- Excellent temperature resistance
- Fast response.
- Increased power density.
- Low rotor inertia.

All the axes in a CNC machine are controlled by servomotors. The movement along different axes is required either to move the cutting tool or the work material to the designed positions.

In order to accomplish accurate control of position and velocity, stepper motors are used for axis drive. The use of stepper motor considerably simplifies the system as feedback devices are not used. The steppers motors are suitable only for light-duty machines due to low power output.

Mechanical transmission systems :

The mechanical transmission system of a feed drive consists of the following elements:

- Elements to convert the rotary motion to a linear motion (Recirculating ball screw nut or rack-and-pinion system).
- Elements to transmit torque (gear box or timing belt and couplings).

To keep the transmission error to a minimum is the primary requirement in the design of a mechanical transmission system. To achieve this, the following requirements are essential :

- Low friction.
- Sufficient damping.
- High natural frequency.
- High Stiffness.
- Backlash free operation.

SPINDLE AND SPINDLE BEARING

The spindle carrying the work piece or tool when subjected to high cutting speeds and high material removal rates, experience deflection and thrust forces. To ensure increased stability and minimize torsional strain, the machine spindle is designed to be short and stiff and the final drive to the spindle is located as near to the front bearing as possible.

The rotational accuracy of the spindle is dependent on the quality and design of bearings used. The ball or roller bearings are suitable for high speeds and high loads because low friction, lower wear rate and lesser liability to incorrect adjustment and ease of replacement when necessary.

Spindle bearings

In modern machine tools, which employ high performance cutting tool material designed characteristics of spindles used, are:

- Minimum deflection under varying loads.
- Long service life.
- Stiffness.
- Thermal stability.
- Good running accuracy both in radial and axial directions.
- Axial load carrying capacity.
- High speed of operation, without chatter, vibration

On these characteristics do the accuracy and quality of the jobs produced depend. This can be achieved by using proper spindle bearing. The various types of spindle bearings used in the design of a spindle for machine tools are:

1. Antifriction bearings.
2. Hydrostatic bearings.
3. Hydrodynamic bearings.

1. **Antifriction bearings:**

The antifriction bearings are suitable for high speeds and high loads.

These are often preferred to hydrodynamic bearings because the following reason

- High reliability.
- Ease of replacement.
- Low friction.
- Moderate dimensions.
- Lesser liability to suffer from wear or incorrect adjustment

On CNC machines, the following types of ball and roller bearings are used:

(i) Ball bearings :

(a) Deep groove ball bearings

(b) Angular contact ball bearings

(ii) Roller bearings:

(i) Cylindrical roller bearings (double row) with tapered bore

(ii) Cylindrical roller bearing

(iii) Tapered roller bearing

- The ball and roller bearings are called anti friction bearings because the contact of support of rolling element is point contact in case of ball bearing and line contact in case of roller bearing. It is of paramount importance that these bearing are manufactured with highest accuracy otherwise any error in any of the elements will severely affect the quality of jobs produced.

The selection of particular type of bearing for the spindle depends on the following requirements of the particular machine :

- Spindle stiffness.
- Spindle accuracy.
- Speeds of operation

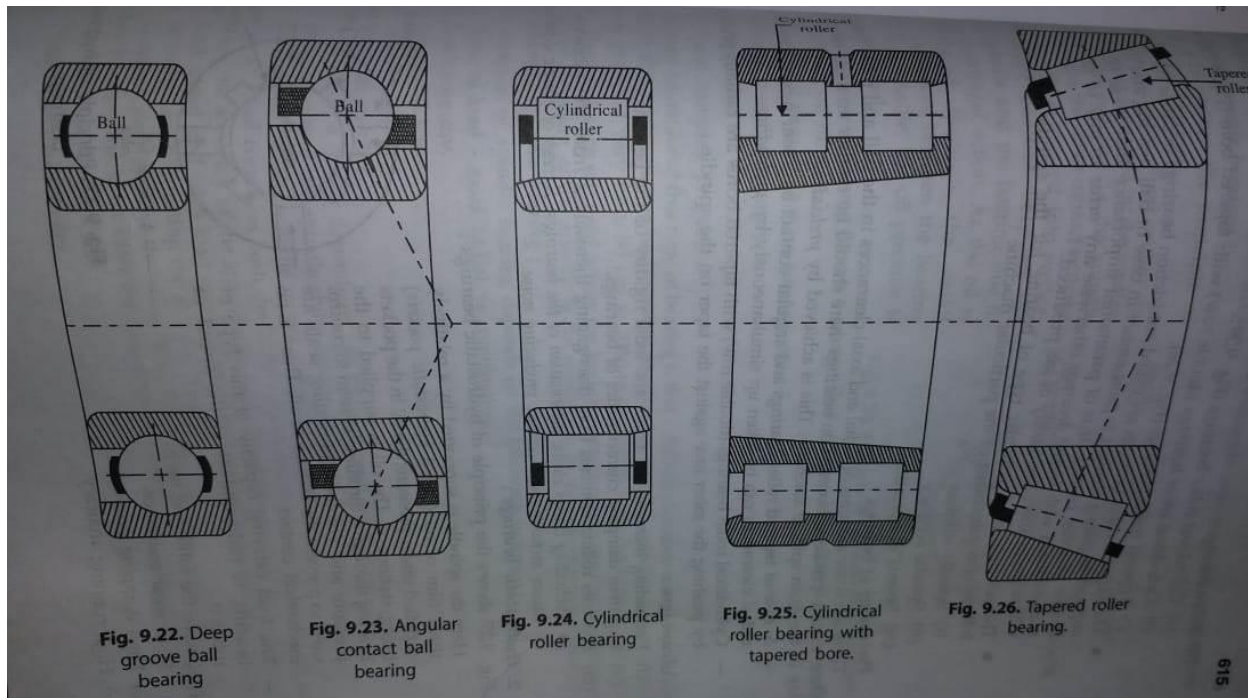

Hydrostatic bearings:

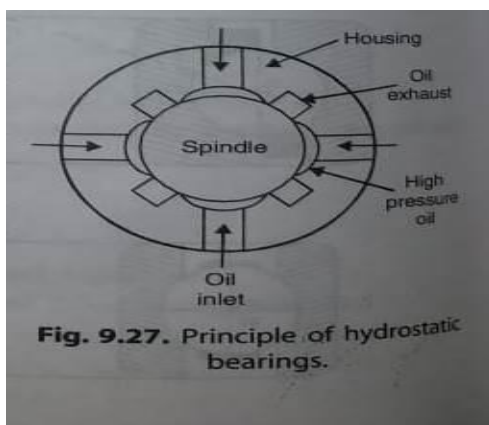

Here the spindle is supported by a relatively thick film of oil (called hydrostatic pockets) supplied under pressure; the oil in the pockets being stationary. The oil is supplied to the bearing through a throttling system to control pressure and volume. Lubricating seals are used to prevent the leakage of oil. There is no mechanical contact.

The load carrying capacity of this type of bearing is independent of the speed of rotation. They have the following merits

- High wear resistance.
- High damping properties.
- High running accuracy.

These bearings are used in grinding and boring machines etc. (where temperature causes problems in the part accuracy).

3. Hydrodynamic bearings:

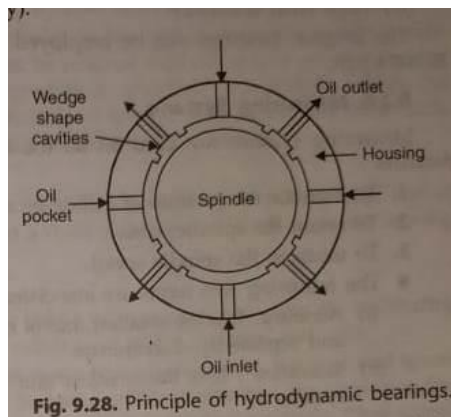

The pressure of oil within the bearing is created by the rotation of the spindle. As the spindle rotates, the oil in contact with the spindle is carried into wedge shape cavities between the spindle and the bearing due to centrifugal action. As the oil is forced through the small clearances between the bearing and spindle, the oil pressure is increased.

- In this type of bearing there is a constant flow of oil round a thick oil film. The essential features of these bearings are

- Good running accuracy.
- Simplicity
- Good damping properties